



BFlex™ 2

Single-Use Bronchoscopes with GlideScope® Video Monitor

Operations & Maintenance Manual

BFlex
verathon

BFlex 2

Single-Use Bronchoscopes with GlideScope Video Monitor Operations & Maintenance Manual

Effective: June 5, 2023

Caution: Federal (United States) law restricts this device to sale by or on the order of a physician.

Contact Information

To obtain additional information regarding your GlideScope system, please contact Verathon Customer Care or visit [verathon.com/service-and-support](https://www.verathon.com/service-and-support).

Verathon Inc.

20001 North Creek Parkway
Bothell, WA 98011 U.S.A.
Tel: +1 800 331 2313 (US and Canada only)
Tel: +1 425 867 1348
Fax: +1 425 883 2896
[verathon.com](https://www.verathon.com)



Verathon Medical (Canada) ULC

2227 Douglas Road
Burnaby, BC V5C 5A9
Canada
Tel: +1 604 439 3009
Fax: +1 604 439 3039

Copyright © 2023 by Verathon Inc. All rights reserved. No part of this manual may be copied or transmitted by any method without the express written consent of Verathon Inc.

GlideScope, BFlex, Verathon, and all associated symbols are trademarks of Verathon Inc. All other brand and product names are trademarks or registered trademarks of their respective owners.

Not all Verathon Inc. products shown or described in this manual are available for commercial sale in all countries.

Information in this manual may change at any time without notice. For the most up-to-date information, see the documentation available at [verathon.com/service-and-support](https://www.verathon.com/service-and-support).

Table of Contents

- IMPORTANT INFORMATION 1**
 - Product Description 1
 - Statement of Intended Use 1
 - Intended Patient Population 1
 - Intended Use Environment and User Population 1
 - Contraindications 1
 - Essential Performance 2
 - Environments of Intended Use 2
 - Statement of Prescription 2
 - Notice to All Users 2
 - Warnings & Cautions 2

- INTRODUCTION 11**
 - Parts & Accessories 12
 - Language Settings 14
 - Bronchoscope Components 15
 - Video Monitor Buttons, Icons, & Connections 16

- SETTING UP 19**
 - Perform Initial Inspection* 19
 - Mount the System (Optional)* 20
 - Charge the Monitor Battery* 23
 - Attach the Video Cable to the Monitor* 24
 - Attach the Bronchoscope to the Video Cable* 24
 - Connect to an External Monitor (Optional)* 26
 - Configure User Settings* 27
 - Perform a Functional Check* 28

USING THE DEVICE 30

- Procedure 1. Prepare the GlideScope System..... 31*
- Procedure 2. Position the Handle and Controls 32*
- Procedure 3. Insert Through a Tube or Catheter (Optional)..... 33*
- Procedure 4. Insert and Flex the Bronchoscope 34*
- Procedure 5. Introduce Liquids or Accessories (Optional)..... 35*
- Procedure 6. Use the Record & Snapshot Features (Optional)..... 37*
- Procedure 7. Remove the Bronchoscope..... 38*
- Procedure 8. Use the Playback Feature (Optional)..... 39*

REPROCESSING 40

MAINTENANCE & SAFETY 41

- Periodic Inspections 41
- GlideScope Video Monitor Battery..... 41
- System Software 41
- Device Repair 42
- Device Disposal..... 42

WARRANTY 43

PRODUCT SPECIFICATIONS 45

- Component Specifications 45
- Battery Specifications..... 53
- Electromagnetic Compatibility..... 54

GLOSSARY 57

Important Information

Product Description

The BFlex 2 Single-Use bronchoscope system includes the following components:

- Single-use bronchoscope
- Reusable monitor
- Reusable cable

The BFlex 2 device is a single-use bronchoscope which, when connected to a video monitor through a reusable cable, is intended to provide real time viewing and recording for a wide range of airway procedures.

Statement of Intended Use

BFlex 2 Single-Use bronchoscopes are intended to work with a video monitor, in conjunction with non-powered endoscopic accessories and other ancillary equipment, for endoscopy within the airways and tracheobronchial tree.

Intended Patient Population

The BFlex 2 Single-Use system is for use in a hospital environment. All four BFlex 2 bronchoscopes are single-use devices designed for use in adults. BFlex 2 Ultraslim 2.8 and Slim 3.8 bronchoscopes are also designed for pediatric use. The BFlex 2 Ultraslim 2.8 has been tested at 6 months to 6 years and the BFlex 2 Slim 3.8 has been tested at 6 years. All BFlex 2 Single-Use bronchoscopes have been verified and validated for the following endotracheal tube (ETT) and endoscope accessory (EA) sizes:

MODEL	MINIMUM ETT INSIDE DIAMETER	EA MINIMUM WORKING CHANNEL WIDTH
BFlex 2 Ultraslim 2.8	4.0 mm	—
BFlex 2 Slim 3.8	5.0 mm	1.2 mm
BFlex 2 Regular 5.0	6.0 mm	2.2 mm
BFlex 2 Large 5.8	7.0 mm	3.0 mm

Note: There is no guarantee that instruments selected solely using these instrument dimensions will be compatible in combination.

Intended Use Environment and User Population

The BFlex 2 Single-Use Bronchoscope is intended for in-hospital use by physicians trained in the use of endoscopic equipment.

Contraindications

The BFlex 2 Ultraslim 2.8 Single-Use Bronchoscope does not have a working channel and therefore cannot be used for therapeutic purposes.

Essential Performance

The essential performance of the BFlex 2 Single-Use bronchoscope is visualization of the airway and tracheobronchial tree as well as certain procedures such as suction and use of endoscopic accessories sized to work with the dimensions of the bronchoscope.

Environments of Intended Use

The BFlex 2 Single-Use bronchoscope system is intended to be used in professional healthcare environments such as hospitals.

Statement of Prescription

Caution: Federal (United States) law restricts this device to sale by or on the order of a physician.

Notice to All Users

Verathon recommends that all users do the following:

- Read the manual before using the equipment.
- Obtain instruction from a qualified individual.
- Practice using the bronchoscope on a mannequin before clinical use.
- Acquire clinical training experience on patients without airway abnormalities.

Warnings & Cautions

Warnings indicate that injury, death, or other serious adverse reactions may result from use or misuse of the device. *Cautions* indicate that use or misuse of the device may cause a problem, such as a malfunction, failure, or damage to the product.

Warnings: Use



WARNING

Before every use, ensure that the instrument is operating correctly and has no sign of damage. Do not use this product if the device appears damaged. Refer servicing to qualified personnel.

Always ensure that alternative airway management methods and equipment are readily available.

Report any suspected defects to Verathon Customer Care. For contact information, visit verathon.com/service-and-support.

**WARNING**

No modification of this equipment is allowed.

**WARNING**

Do not use the power adapter in the presence of flammable anesthetics.

**WARNING**

Verathon has conducted no analysis to establish the compatibility of the system with environments where magnetic resonance imaging (MRI) equipment is installed. Because of this, the owner of the system must exclude it from any magnetic resonance (MR) environment.

**WARNING**

The video signals produced and used by this system are intended for device positioning only. Do not use the system as the sole diagnostic method of any pathology.

**WARNING**

Do not use this system during defibrillation.

**WARNING**

This instrument and related devices may contain batteries or other environmentally hazardous materials. When the instrument or accessories have reached the end of their useful service life, see the section Device Disposal. Dispose of used, single-use components as infectious waste.

**WARNING**

Monitor Only: Use only a passive-type USB flash drive. Do not use USB drives powered by another external source.

**WARNING**

Monitor Only: The external monitor must be safety-approved medical equipment.



WARNING

Two areas of the bronchoscope tip that contact the patient can exceed 41°C (106°F) as part of normal operation:

The first area is the light-emitting area surrounding the camera in the tip. When used as indicated, continuous contact with this area is unlikely because, if tissue were to contact this area, a usable view would be lost. Devices would then need to be adjusted to regain the working distance needed for a usable view.

The second area is the area of the tip that surrounds the camera, but is out of its field of view. Continuous contact with this area is unlikely because the product is typically not held stationary for an extended period of time, and because there is normally a small clearance between the area and the adjacent tissue.

To prevent thermal damage, such as a burn to the mucosal tissue, avoid prolonged, continuous contact with these areas of the bronchoscope tip.



WARNING

Do not use this system to deliver highly flammable anaesthetic gases to the patient. Such use may result in patient injury.



WARNING

When using suction, limit the vacuum level to 85 kPa (638 mmHg) or less. Higher vacuum levels may make it difficult to cut off suction if required.



WARNING

Do not use active endoscopic components such as laser probes or electrosurgical devices with this system. Such use may result in injury to the patient or damage to the system.



WARNING

Do not introduce accessories that exceed the maximum accessory width shown in the Product Specifications section or on the package label of the bronchoscope.



WARNING

Do not advance the bronchoscope while endoscopic accessories extend out of the opening in the distal tip. The resulting accessory movements may result in patient injury.

**WARNING**

Use caution when withdrawing endoscopic accessories from the patient.

**WARNING**

Before withdrawing the bronchoscope, place the distal tip into a straight, neutral position. While withdrawing, do not touch the control lever. Any bend in the distal tip may result in patient injury.

**WARNING**

If a malfunction should occur during use, do not continue the procedure. Place the distal tip into a straight, neutral position, and then slowly withdraw the bronchoscope without touching the control lever.

**WARNING**

Always watch the video display carefully while advancing or withdrawing the bronchoscope, flexing the distal tip, or applying suction. Failure to do so may result in injury to the patient.

**WARNING**

Before discarding a bronchoscope, ensure that no parts of the camera, distal tip, or insertion tube are missing.

Warnings: Reprocessing



WARNING

Do not reuse, reprocess, or resterilize single-use components. Reuse, reprocessing, or resterilization may create a risk of contamination of the device.



WARNING

QuickConnect Cable, Monitor, and Cart Only: Availability of cleaning products varies by country, and Verathon is unable to test products in every market. For more information, please contact Verathon Customer Care. For contact information, visit verathon.com/service-and-support.



WARNING

QuickConnect Cable, Monitor, and Cart Only: This product may only be cleaned or disinfected by using the approved processes provided in the GlideScope and GlideRite Products Reprocessing Manual (part number 0900-5032). Cleaning and disinfection methods listed are recommended by Verathon based on efficacy or compatibility with component materials.



WARNING

QuickConnect Cable, Monitor, and Cart Only: For information on the handling and disposing of recommended reprocessing solutions, please refer to the solution manufacturer's instructions.

Warnings: Electrical



WARNING

To maintain electrical safety, use only the provided power supply. Connect the power cord and power adapter to a properly grounded plug, and ensure that the disconnect is easily accessible. Use only the accessories and peripherals recommended by Verathon.



WARNING

Electric shock hazard. Do not attempt to open the system components. This may cause serious injury to the operator or damage to the instrument and voids the warranty. Contact Verathon Customer Care for all servicing needs.



WARNING

Power Adapter Only: Electric shock hazard. Do not immerse the power adapter in water. When cleaning the power adapter, use a cloth dampened with isopropyl alcohol on the outside of the enclosure.



WARNING

Use of accessories and cables other than those specified or provided by Verathon may cause this system to experience electromagnetic malfunctions, including increased emissions or decreased immunity. This may cause improper operation, procedure delays, or both.



WARNING

Portable radio frequency communications equipment (including peripherals such as antenna cables and external antennas) may not be used within 30 cm (12 inches) of any part of the BFlex 2 Single-Use Bronchoscope system, including cables that Verathon specifies or provides for use with the system. If this distance is not maintained, performance of the system may be degraded and image display may be compromised.

Cautions: Use



CAUTION

Do not use a knife or other sharp instrument to open the packaging containing the bronchoscope, and do not use the bronchoscope if its packaging is damaged.



CAUTION

Before using an endoscopic accessory, ensure it is compatible with the working channel of the bronchoscope.



CAUTION

Do not use the system if it is not functioning properly or if it is damaged in any way.



CAUTION

Do not store BFlex 2 pouches in direct sunlight.



CAUTION

European Union only: If any serious incident occurs during use of this product, you must immediately notify Verathon (or its authorized representative), the Competent Authority of the Member State where the incident occurred, or both.



CAUTION

The BFlex 2 3.8 Single-Use Bronchoscope should not be used with 35Fr Shiley Endobronchial Tubes. Damage or tear to the BFlex 2 tip sheath may occur.



CAUTION

Do not use a BFlex holder as a handle when moving the Workstation. Using a BFlex holder as a handle may damage the holder.



CAUTION

Do not use excessive force when inserting, positioning, or removing the single-use bronchoscope or accessories. Using excessive force against resistance could result in product damage, including damage to or detachment of the distal tip.

Cautions: Reprocessing



CAUTION

QuickConnect Cable Only: For information on the handling and disposing of recommended reprocessing solutions, please refer to the solution manufacturer's instructions.



CAUTION

Risk of permanent equipment damage. This product is sensitive to heat, which causes damage to the electronics. Do not expose the system to temperatures above 45°C (113°F), and do not use autoclaves or pasteurizers. Use of such methods to clean or disinfect the system causes permanent device damage and voids the warranty. For a list of approved cleaning procedures and products, see the GlideScope Products Reprocessing Manual (part number 0900-5032).



CAUTION

Monitor Only: The system contains electronics that may be damaged by ultrasonic and automated washing equipment. Do not use an ultrasonic device or automated washing equipment to clean this product.

Cautions: Electrical



CAUTION

Medical electrical equipment requires special precautions regarding electromagnetic compatibility (EMC) and must be installed and operated according to the instructions in this manual. For more information, see the Electromagnetic Compatibility section.

Avoid using the GlideScope system adjacent to or stacked with other equipment. If adjacent or stacked use is necessary, observe the system to verify normal operation in the configuration in which it will be used.

This device can radiate radio frequency energy and is highly unlikely to cause harmful interference with other devices in the vicinity. There is no guarantee that interference will not occur in a particular installation. Evidence of interference may include degradation of performance in this device or other devices when operated simultaneously. If this occurs, try to correct the interference and restore optimal image quality by using the following measures:

- Turn devices on and off in the vicinity to determine the source of interference
- Reorient or relocate this device or other devices
- Increase the separation between devices
- Power off and on the monitor if the image quality is not optimal after removal of the interference
- Connect the device to an outlet on a circuit different than the other device(s)
- Eliminate or reduce EMI with technical solutions (such as shielding)
- Purchase medical devices that comply with IEC 60601-1-2 EMC standards

Be aware that portable and mobile radio frequency communications equipment (cellular phones, etc.) may affect medical electrical equipment; take appropriate precautions during operation.

Introduction

The BFlex 2 Single-Use Bronchoscope system incorporates the following central components:

- BFlex 2 bronchoscope (single-use)
- GlideScope Video Monitor QuickConnect Cable (reusable)
- GlideScope Video Monitor (reusable)

The system also includes the cables and adapters to power the monitor, and it may include optional system components that simplify use or provide convenience to the user.

Figure 1. BFlex 2 Single-Use System



Parts & Accessories

Table 1. Required System Components

REQUIRED PARTS AND ACCESSORIES			
GlideScope Video Monitor			
			
BFlex 2			
BFlex 2 Ultraslim 2.8 Single-Use bronchoscope			
			
BFlex 2 Slim 3.8 Single-Use bronchoscope			
			
BFlex 2 Regular 5.0 Single-Use bronchoscope			
			
BFlex 2 Large 5.8 Single-Use bronchoscope			
			
Accessories			
GlideScope Video Monitor QuickConnect Cable			
			
Introducer	In-service USB flash drive <i>Note: Contains instructions for use.</i>	Video monitor 12V DC power adapter	Power cable
			

Table 2. Optional System Components

OPTIONAL PARTS & ACCESSORIES		
<p>Premium cart</p> 	<p>Mobile stand</p> 	
<p>Media storage USB flash drive</p> 	<p>Universal accessory basket <i>Note: For use with mobile stand</i></p> 	
<p>HDMI-to-DVI cable</p> 	<p>IV pole mounting kit for monitor</p> 	<p>BFlex holder</p> 

Language Settings

The video monitor software is available in a variety of languages. To change the language used on your system, you must install a new software version via a USB flash drive. For more information, contact Verathon Customer Care or your local representative. For contact information, see verathon.com/global-support.

Bronchoscope Components

The BFlex 2 bronchoscope is a single-use device that can be inserted either directly or through an endotracheal (ET) tube. The main components of the bronchoscope are shown in the following figure.

Figure 2. Bronchoscope Components

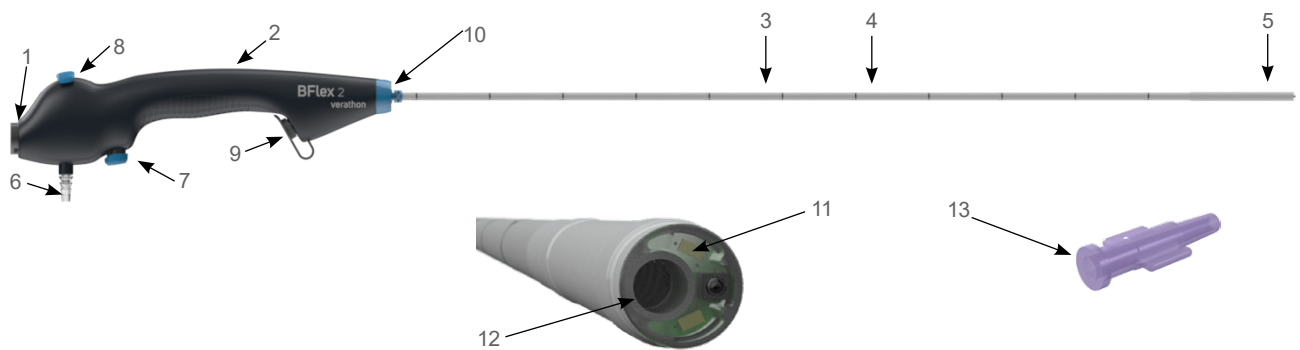

Table 3. Bronchoscope Component Descriptions

FIGURE KEY	COMPONENT	NOTES
1	Cable connector	Includes magnetic quick release.
2	Handle	—
3	Insertion tube	—
4	Positioning marks	Includes marks at 5 cm (50 mm) intervals to assist in scope placement within the airway.
5	Articulating distal tip	—
6*	Suction port	Accommodates tubing with an inside diameter between 6.0 and 7.0 mm, inclusively.
7*	Suction button	—
8	Control lever	Positions articulating distal tip.
9*	Accessory port and accessory port cap	Enables introduction of accessories or liquids.
10	Tube retainer	Enables mounting of endotracheal (ET) tubes with standard ISO connectors (and endobronchial double lumen [DL] tubes for BFlex 2 Slim 3.8 and Ultraslim 2.8).
11	Camera and light	High-resolution, full-color camera with integrated LED light source and anti-fog protection.
12*	Working channel	—
13*	Introducer	Connects Luer syringes securely to the accessory port.

* Does not apply to BFlex 2 Ultraslim 2.8.

Video Monitor Buttons, Icons, & Connections

The digital, full-color GlideScope Video Monitor clearly displays the images transmitted from the camera in the bronchoscope. The front of the monitor includes the screen and a keypad with the buttons you use to operate the system.

The back panel of the monitor includes the sockets and ports for connecting the power cord, the GlideScope Video Monitor QuickConnect Cable, an HDMI-to-DVI cable for external video display, and a USB flash drive. When a socket or port is not in use, it is recommended that the rubber cap be inserted into the opening. This protects the exposed connectors from dust and contamination. The back of the video monitor also features a mounting plate fitting that allows you to attach the monitor to a mobile stand or IV pole.

Figure 3. GlideScope Video Monitor Keypad

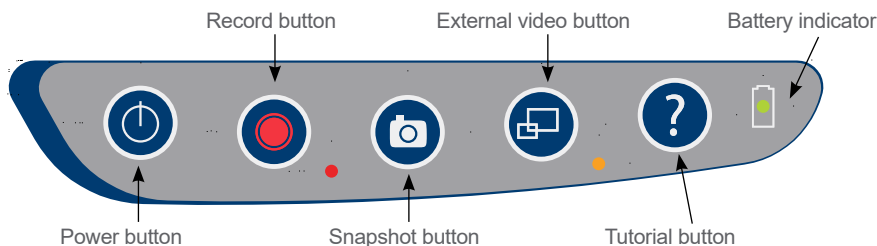

Table 4. Keypad Buttons



















BUTTON	FUNCTION
	Power: Press and release to turn on the monitor. Press and hold to turn it off. <i>Note: If the monitor freezes at any time during use, press and hold the Power button for 10 seconds to reset the system.</i>
	Record: Press to start and stop recording directly to a USB flash drive that has been inserted in the USB port. When you are recording, the red LED indicator to the right of the button will be lit, and the Recording icon  will be shown on the screen. The playback menu is not available during recording. <i>Note: To record video, a USB flash drive must be inserted into the monitor USB port.</i>
	Snapshot: Press this button to save a snapshot of the live display to the USB flash drive. You may take a snapshot while video recording or independent of recording. <i>Note: To take a snapshot, a USB flash drive must be inserted into the monitor USB port.</i>
	External Video: Press to display video on an external monitor. The yellow LED to the right of the button will light up to indicate that the key has been activated. Press the key again to deactivate the external video. <i>Note: An HDMI-to-DVI cable is required in order to display video on an external monitor.</i>
	Tutorial: If no USB flash drive is connected, hold for 3 seconds to view the video tutorial. If a USB flash drive is connected, hold for 3 seconds to enter the playback menu. During the 3-second delay, press the Snapshot button to enter the User Settings screens.
	Battery Indicator: LED is: Green: Unit fully charged Red: Unit charging Flashing Red: Indicates a problem with the battery. Charge for 6 hours, and if still flashing, contact Verathon Customer Care.

Table 5. On-Screen Icons

ICON	FUNCTION
	<p>Battery Status: The remaining battery power is indicated by the Battery Status icon and the percentage above the icon. If the icon is red, the battery should be charged as soon as possible. (See Charge the Monitor Battery on page 23.) While the battery is being charged, a lightning bolt will be displayed alongside the Battery Status icon.</p>
	<p>Progress Confirmation: While the user is pressing a button, the operation is loading. If the button is released before the loading process is completed, the operation is canceled.</p>
	<p>Power-Down Countdown: The unit is about to turn off. If this is due to the Auto Power Off feature that saves battery life, pressing any button stops the power-down sequence.</p> <p><i>Note: The Auto Power Off feature can be adjusted or disabled on the User Settings screen. For more info, see Configure User Settings on page 27.</i></p>
	<p>USB Flash Drive: A USB flash drive is detected.</p> <p>While recording, a number next to the icon indicates approximately what percentage of the USB flash drive has been used. When the USB flash drive is full, recording stops.</p>
	<p>Incompatible USB Drive: The USB flash drive that is plugged into the monitor is not suitable for recording videos. (This normally occurs when using an encrypted USB flash drive or when using an older, inexpensive model that is not capable of the speed necessary to save video in real time.)</p>
	<p>USB Flash Drive Not Found: A USB flash drive needs to be inserted into the monitor USB port.</p>
	<p>Attach GlideScope Video Monitor QuickConnect Cable: The GlideScope Video Monitor QuickConnect Cable is not properly attached to the monitor.</p>
	<p>Recording: The system is recording video to the USB flash drive.</p> <p><i>Note: Do not remove the USB flash drive while recording is in progress, or the recording will be lost.</i></p>
	<p>Saving Snapshot: The system is saving a snapshot to the USB flash drive.</p> <p><i>Note: Do not remove the USB flash drive while saving a snapshot, or the snapshot will be lost.</i></p>
	<p>Saving File: The system is saving a recorded file to the USB flash drive.</p> <p><i>Note: Do not remove the USB flash drive while this icon is displayed, or the recording will be lost.</i></p>
	<p>External Monitor: The HDMI-to-DVI connection for external video is enabled, and video is being displayed on an external monitor.</p>









ICON	FUNCTION
	Hourglass: Please wait while the system prepares for the next action.
	Audio Recording is Active: Audio is being recorded on the video. <i>Note: The default for audio recording is OFF. Audio recording on the video occurs only if the setting has been changed to ON in user settings.</i>
	Back Arrow: Exit to previous screen.
	Up Arrow: Select previous file for playback.
	Down Arrow: Select next file for playback.
	Play: Play the selected file or continue playing a paused video file. <i>Note: This option is not available while audio recording is active.</i>
	Pause: Pause the video playback.
	Snapshot: On the playback menu, this icon indicates that a file is a snapshot.
	Video: On the playback menu, this icon indicates that a file is a video.

Figure 4. GlideScope Video Monitor Back Panel



Setting Up

Before you can use the system for the first time, you must inspect the components, set up the system, and perform a functional test as recommended by Verathon. Complete the following tasks:

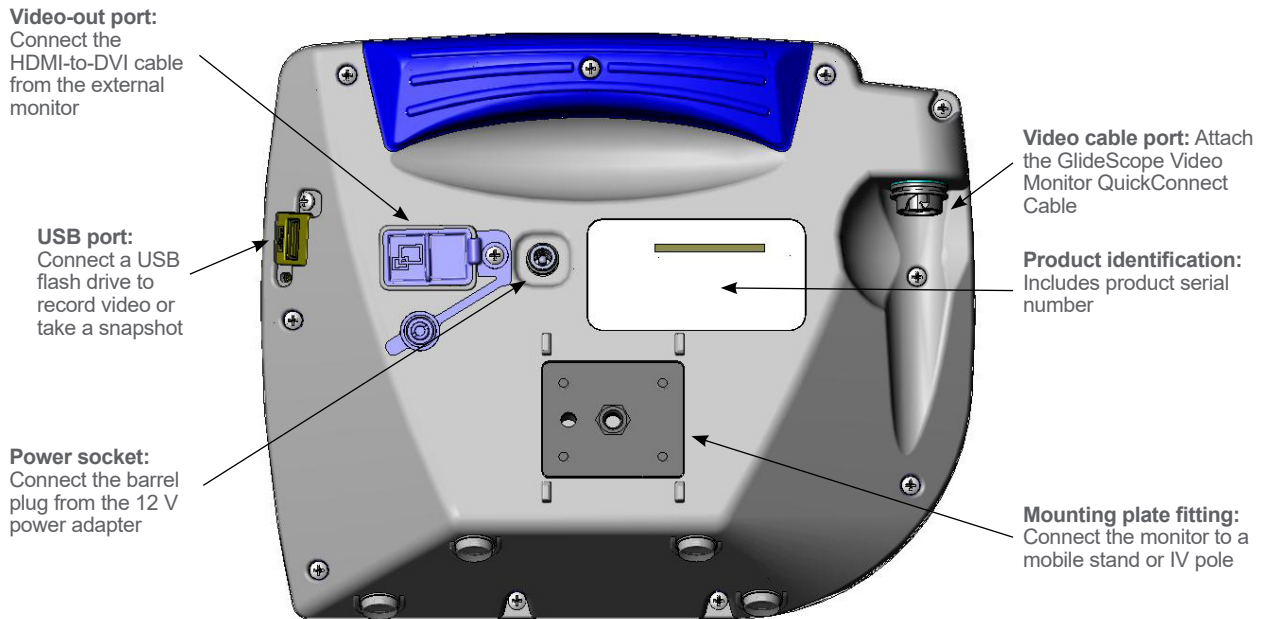
1. **Perform Initial Inspection**—Inspect the system for any obvious physical damage that may have occurred during shipment.
2. **Mount the System (Optional)**—Set up the GlideScope Video Monitor on a mobile stand or IV pole.
3. **Charge the Monitor Battery**—Note that you can use the system while the battery is charging.
Note: The monitor will operate without charging the battery by using the GlideScope Video Monitor 12V DC power adapter that shipped with the unit.
4. **Attach the Video Cable to the Monitor**—Connect the QuickConnect cable to the monitor.
5. **Attach the Bronchoscope to the Video Cable**—Connect the bronchoscope to the cable.
6. **Connect to an External Monitor (Optional)**—Connect the monitor to an external display source, such as a larger monitor screen, by using the HDMI-to-DVI cable.
7. **Configure User Settings**—Enter data customized to your clinic, and configure settings such as the date and time.
8. **Perform a Functional Check**—Before you use the device for the first time, perform a functional check to ensure that the system is working properly.

Perform Initial Inspection

When you receive the system, Verathon recommends that an operator familiar with the instrument perform a full visual inspection of the system for any obvious physical damage that may have occurred during shipment.

1. Verify that you have received the appropriate components for your system by referring to the packing list included with the system.
2. Inspect the components for damage.
3. If any of the components are missing or damaged, notify the carrier and Verathon Customer Care or your local representative. For contact information, visit verathon.com/service-and-support.

Mount the System (Optional)

If you choose to mount the system, you may use either of the following configurations:

- Mount it on a GlideScope premium cart or mobile stand (Figure 5 or Figure 6). These solutions make it easy for you to move the system from one location to another.
- Mount it on an IV pole (Figure 7).

Figure 5. GlideScope Premium Cart



Figure 6. Mobile Stand

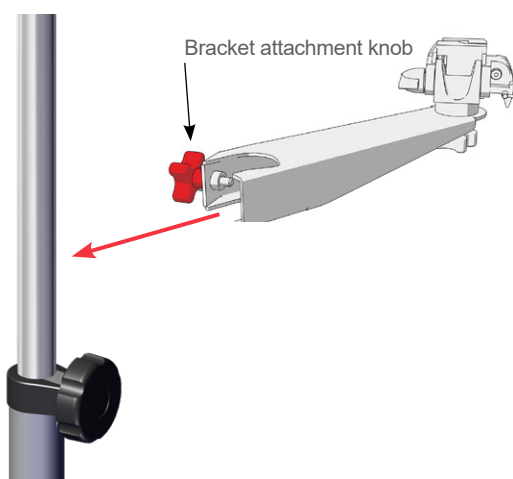

Figure 7. IV Pole Mount



ATTACH THE MONITOR TO THE CART OR IV POLE

1. If you are using the GlideScope premium cart or mobile stand, assemble it according to the instructions included with the component.
2. If you are using an IV pole mount, place the mounting bracket on the IV pole, and then tighten the bracket attachment knob until the IV pole mount is secure.



3. On the cart mount or the IV pole mount, ensure that the locking pin and quick-release lever are in the unlocked (horizontal) position.

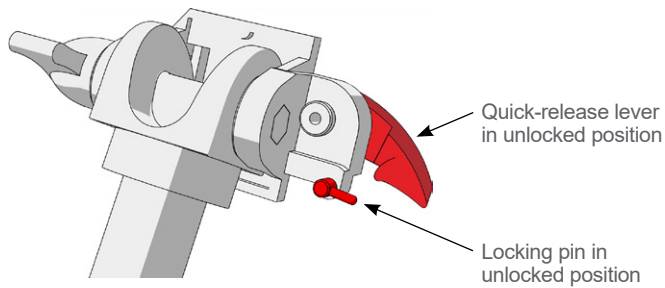

4. While holding the quick-release locking plate with the head of the mounting screw facing away from you and the larger of the two flanges to your left, insert a positioning pin into the right-hand hole on the locking plate as shown in the following image.

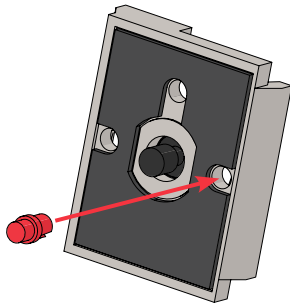

5. Using the orientation shown in the following images, screw the quick-release locking plate to the back panel of the monitor.

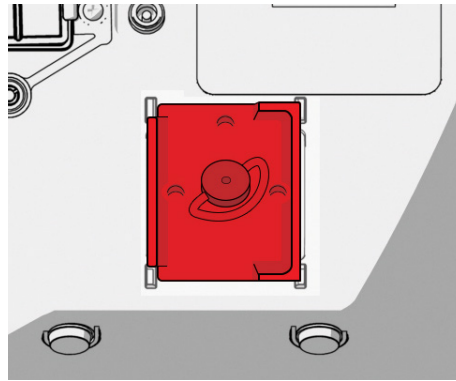
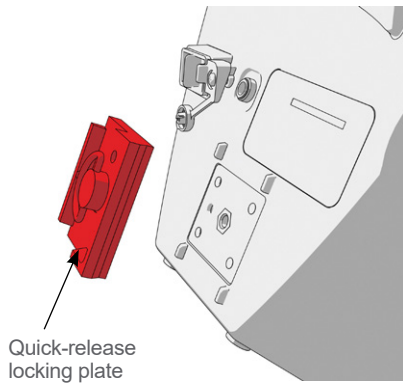

6. Seat the locking plate of the monitor on the quick-release mount. When properly situated, the monitor sits securely on the mount, and the quick-release lever automatically snaps into the locked (down) position.

7. Ensure that the quick-release lever is fully in the locked (down) position. This secures the monitor in place.

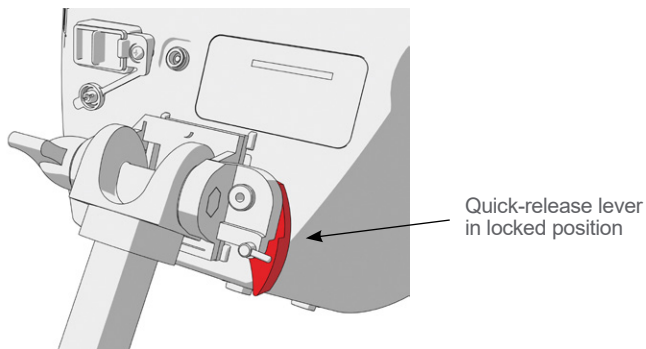

8. Adjust the locking pin to the locked (down) position. This secures the quick-release lever in the locked position.

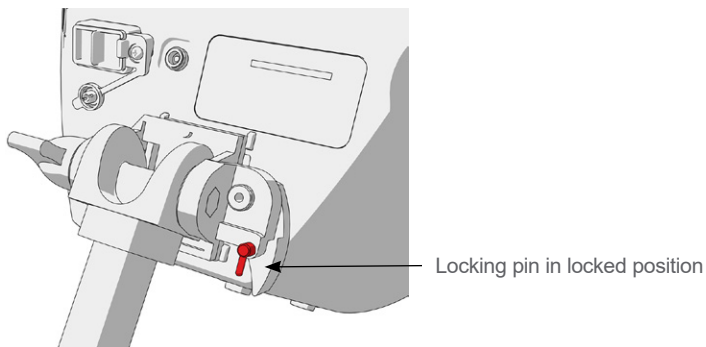

ADJUST THE MONITOR ANGLE

Before you start using the video monitor, adjust the angle of the monitor for optimal viewing. The ideal angle minimizes glare and maximizes visibility.

9. Turn the angle adjustment knob counterclockwise.

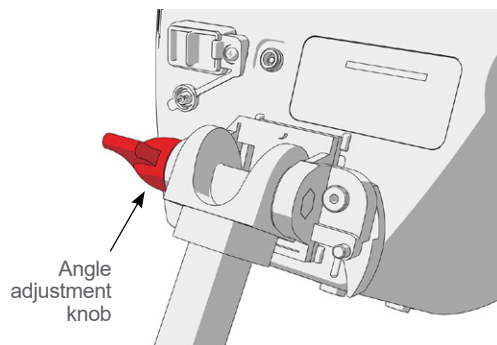

10. Tilt the monitor to the desired angle.
11. Turn the angle adjustment knob clockwise. This secures the monitor at the desired angle.

Charge the Monitor Battery

The GlideScope Video Monitor includes an internal lithium-ion battery. Verathon recommends that you charge the battery fully prior to first use.

Under normal operating conditions, a fully charged battery lasts approximately 90 minutes before it needs to be recharged. For optimal battery life, ensure that the battery is fully charged before you try to use the monitor in battery mode. You should charge the battery at temperatures between 0–35°C (32–95°F).

The percentage above the Battery Status icon indicates the remaining battery charge.

Figure 8. Battery Status Icons

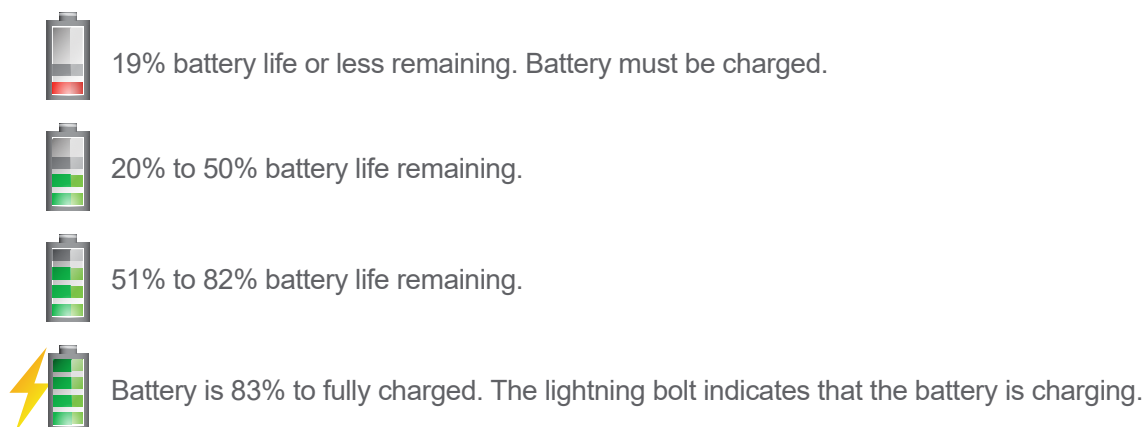

1. Connect the video monitor 12V DC power adapter to the power cable.
2. On the back panel of the monitor, remove the power socket cap, and then connect the 12V DC power adapter to the power socket.

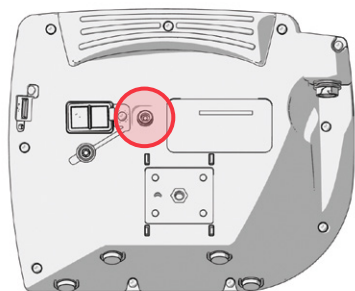

3. Plug the power supply into a hospital-grade power outlet.
4. Allow the battery to charge. Fully charging the battery may take up to 6 hours.

Attach the Video Cable to the Monitor

1. Ensure that the video monitor is turned off.
2. Align the arrow on the video cable and the arrow on the video cable port, and then insert the cable into the port. You will hear a click when the cable is successfully connected.

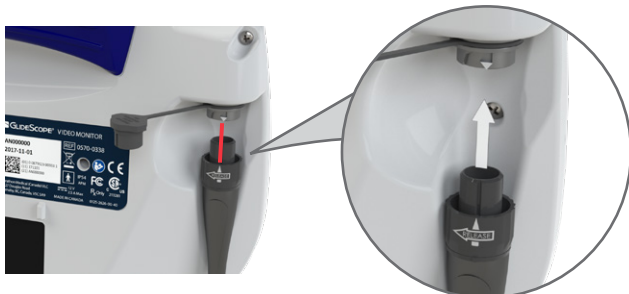

3. To disconnect the video cable from the monitor, rotate the connector ring in the direction of the release arrow, and then remove the connector from the port.



Attach the Bronchoscope to the Video Cable

The GlideScope Video Monitor QuickConnect Cable attaches the bronchoscope to the monitor, supplying power to the bronchoscope and transmitting video data from the camera to the monitor.

It is recommended that you leave the sterile, single-use bronchoscope in the packaging while connecting it, and that you do not remove the bronchoscope until you are ready to insert it. This helps ensure that the bronchoscope remains as clean as possible.

1. If necessary, connect the cable to the monitor according to the procedure [Attach the Video Cable to the Monitor](#) on [page 24](#).
2. Remove the bronchoscope and the introducer from their packets.
3. Detach the protective cover from the cable connector on the bronchoscope. Discard the cover after you remove it.



4. If you are using a BFlex holder, place the BFlex 2 with the protective sleeve in the holder. Otherwise, carefully slide the protective sleeve off the insertion tube of the bronchoscope.



5. Inspect the bronchoscope to ensure that it is not damaged..
6. Align the white dot on the opposite end of the QuickConnect Cable with the dot on the bronchoscope, and then insert the connector into the bronchoscope. Magnets in both components hold them in place during use.

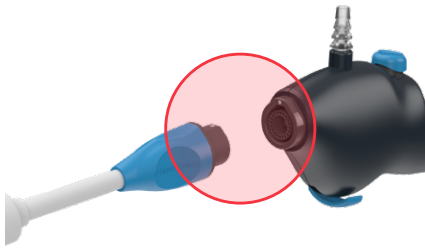

7. To disconnect a bronchoscope from the QuickConnect Cable, hold the cable connector in one hand and the handle of the bronchoscope in the other, and then pull. The bronchoscope disconnects from the cable.

Connect to an External Monitor (Optional)



Please read the [Warnings & Cautions](#) section before performing the following tasks.



By using an HDMI-to-DVI cable, you can connect the GlideScope Video Monitor to an external monitor that is approved for medical use. For more information, please contact your Verathon Customer Care representative.

Note: Image quality on the external monitor may vary according to the resolution of the external monitor.

Note: To maintain electromagnetic interference (EMI) within certified limits, the GlideScope BFlex system must be used with the cables, components, and accessories specified or supplied by Verathon. For additional information, see the [Parts & Accessories](#) section on page 12 and the [Component Specifications](#) section on page 45. The use of accessories or cables other than those specified or supplied may result in increased emissions or decreased immunity of the system.

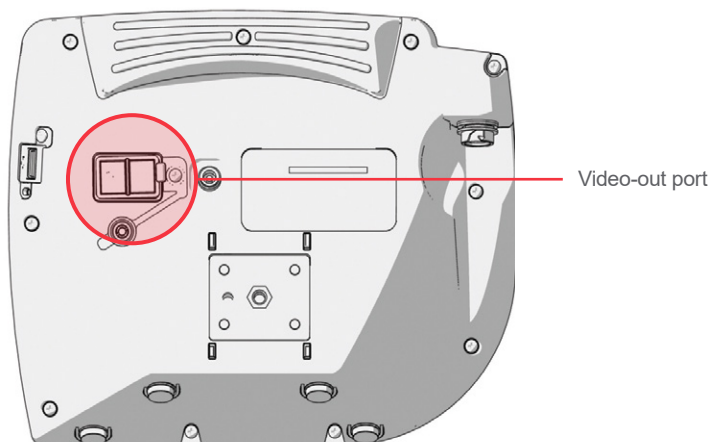
1. Ensure that the video monitor is turned off.
2. On the back of the monitor, remove the HDMI cap from the video-out port.
3. Connect the HDMI end of the cable to the video-out port.



4. Connect the other end of the cable to the DVI port on an external monitor that is approved for medical use.
5. Press the **Power**  button. The monitor turns on.
6. Press the **External Video**  button. The indicator LED to the right of the button illuminates when the connection is successful, and the video displays on the external monitor.
7. To stop sending video to an external monitor, press the **External Video**  button again.
8. Before disconnecting the HDMI-to-DVI cable, ensure the video monitor is turned off.

Configure User Settings

You may configure the following settings directly on the unit:

- Date and Time
- Date and Time Format
- Key Click Sound
- Auto Power Off
- Audio Recording
- Auto Recording
- Auto External Video
- Clinic Name

The second page of user settings, as seen in [Figure 10](#), displays system-use information, and it does not contain any configurable settings.

Figure 9. User Settings Screen Page 1

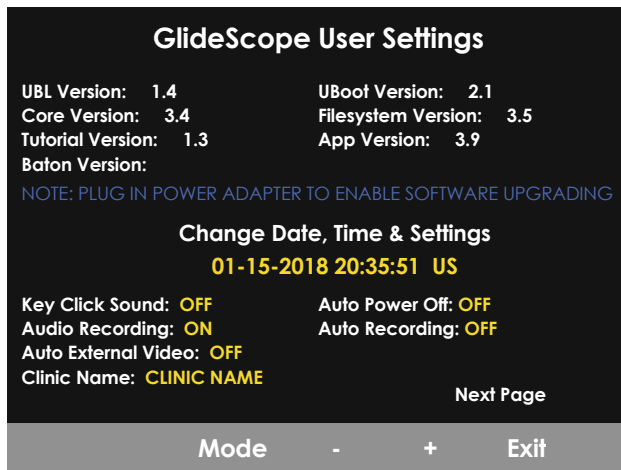
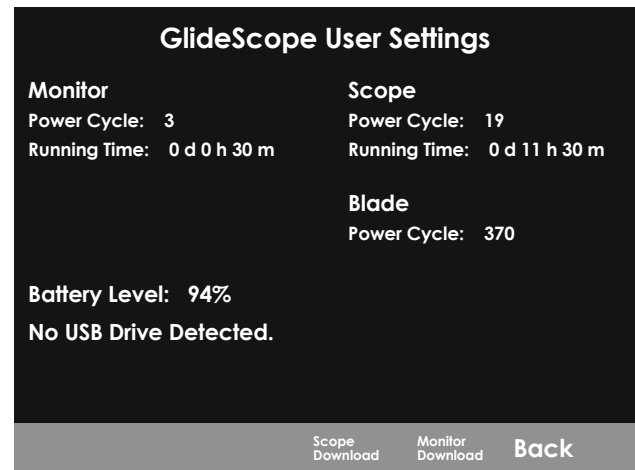















Figure 10. User Settings Screen Page 2



1. If a USB flash drive is inserted into the monitor, remove it.
2. Press the **Power**  button. The monitor turns on.
3. Press and hold the **Tutorial** button , and while continuing to hold it, press the **Snapshot** button  within the first 3 seconds. The User Settings screen appears on the monitor. The configurable user settings are displayed in yellow, and the selected setting is highlighted in red.
4. Customize your user settings by using the following buttons:
 - Press the **Record** button  to select the parameter you want to set.
 - Press the **Snapshot** button  to decrease the parameter value.
 - Press the **External Video** button  to increase the parameter value.
 - When inputting the Clinic Name, the **Tutorial** button  moves the selection to the next letter. Press the **Record** button  twice to return the selection back to the Date/Time setting.
 - To view the second page of user settings, press the **Record** button  until **Next Page** is highlighted in red, and then press the **Tutorial** button . To exit the second page of user settings, press the **Tutorial** button  again.
5. When you are finished customizing the settings, press the **Record** button  until the option **Exit** is available in the gray bar, and then press the **Tutorial** button . This saves the parameters, and the User Settings screen closes.

Perform a Functional Check

Before you use the device for the first time, perform the following functional check to ensure that the system is working properly. Please contact your Verathon Customer Care representative if your system does not function as described below.

REQUIRED CHECKS

1. Fully charge the monitor battery (this takes approximately 6 hours).
2. Attach a GlideScope Video Monitor QuickConnect Cable and a bronchoscope to the monitor, according to the instructions in [Attach the Video Cable to the Monitor](#) on page 24 and [Attach the Bronchoscope to the Video Cable](#) on page 24.
3. Press the **Power**  button. The monitor turns on.
4. Look at the monitor screen, and verify that the image displayed is being received from the bronchoscope.



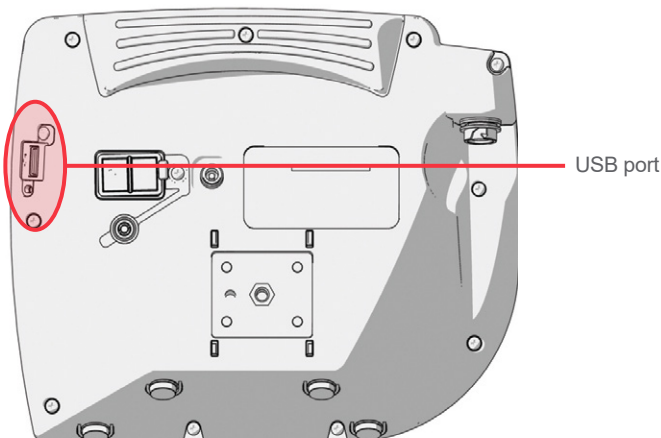

RECOMMENDED CHECKS

5. On the back of the monitor, remove the USB port cap, and then insert a USB flash drive into the port.



6. Ensure that the USB flash drive is detected by checking if the **USB Flash Drive** icon  on the bottom of the screen is displayed.

7. Press the **Record** button . Recording starts.
8. To stop recording, press the **Record** button  again.
9. Wait until the **Saving File** icon  has disappeared from the screen, and then remove the USB flash drive from the monitor.
10. On a computer, verify that the recorded video (.avi) file can be played.

Note:

If you are viewing the recorded file on a Windows operating system (OS), use an application such as one of the following:

- *Windows Media Player* (included with the operating system)
- *VLC* (free at <http://www.videolan.org/vlc/index.html>)

If you are viewing the recorded video file on Mac OS, use an application such as one of the following:

- *MPlayerX* (free in the App Store)
- *VLC* (free at <http://www.videolan.org/vlc/index.html>)

If you are viewing the recorded video file on iOS, use an application such as one of the following:

- *VLC for iOS* (free in the App Store)
- *8player lite* (free in the App Store)
- *Media Player - PlayerXtreme HD* (free in the App Store)

Using the Device

Before use, set up the device according to the instructions in the previous chapter, and verify the setup by completing the procedure [Perform a Functional Check](#) on page 28.



Please read the [Warnings & Cautions](#) section before performing the following tasks.

BFlex 2 Single-Use bronchoscopes are equipped with an anti-fog feature that reduces camera fogging during use. To optimize the feature fully, you must allow the bronchoscope to warm up for 30–120 seconds prior to use, depending on the ambient temperature and humidity of the clinical environment. Full warmup is not necessary to use the device; if desired, you may begin the insertion procedure immediately.

Using the BFlex 2 system consists of the following:

- [Prepare the GlideScope System](#)
- [Position the Handle and Controls](#)
- [Insert Through a Tube or Catheter \(Optional\)](#)
- [Insert and Flex the Bronchoscope](#)
- [Introduce Liquids or Accessories \(Optional\)](#)
- [Use the Record & Snapshot Features \(Optional\)](#)
- [Remove the Bronchoscope](#)
- [Use the Playback Feature \(Optional\)](#)

Note: Follow accepted practices in order to protect the bronchoscope from contamination prior to insertion.

Procedure 1. Prepare the GlideScope System

In this procedure, you turn the system on and verify that it is functioning properly.

1. Ensure that each GlideScope system component has been properly cleaned.
2. Attach the GlideScope Video Monitor QuickConnect Cable and the bronchoscope to the monitor, according to the instructions in the sections [Attach the Video Cable to the Monitor](#) on page 24 and [Attach the Bronchoscope to the Video Cable](#) on page 24.
3. If you need to deliver suction through the working channel of the bronchoscope, connect a suction line to the suction port.*

Note: The inside diameter of the suction tubing should be between 6.0 and 7.0 mm, inclusively.

4. Press the **Power** button . The video monitor turns on.

Note: If the GlideScope Video Monitor locks up, becomes unresponsive for any reason, or does not show an image from the bronchoscope, press and hold the Power button for 10 seconds to reboot the system.

5. Ensure that the battery is sufficiently charged. If necessary, connect the monitor directly to power.
6. On the monitor screen, verify that the image displayed is from the bronchoscope camera.
7. If needed, allow the GlideScope anti-fog feature to warm up for 30–120 seconds.

Note: The time required for the anti-fog feature to be fully optimized varies according to the ambient temperature and humidity where the equipment is being stored or used. If the bronchoscope is stored in cold conditions, additional warming time may be required for optimal performance of the anti-fog feature.

* Does not apply to BFlex 2 Ultraslim 2.8.

Procedure 2. Position the Handle and Controls

With your supporting hand positioned as described in this procedure, you can regulate suction with your index finger and position the distal tip of the bronchoscope with your thumb. You can then use your other hand to introduce accessories or liquids through the working channel, to grasp and turn the insertion tube, or to provide additional support as appropriate. If you need to do several of these things at once, you may need a second person to assist.

1. Empty the hand you will use to support and operate the bronchoscope.
2. Using that hand, grasp the handle in the center.
3. Place the positioning lever under your thumb.
4. Place the suction button under your index finger. Press the button as needed to apply suction.*

Note: To ensure full suction strength, remove any object such as a syringe or an endoscopic accessory from the working channel while applying suction.

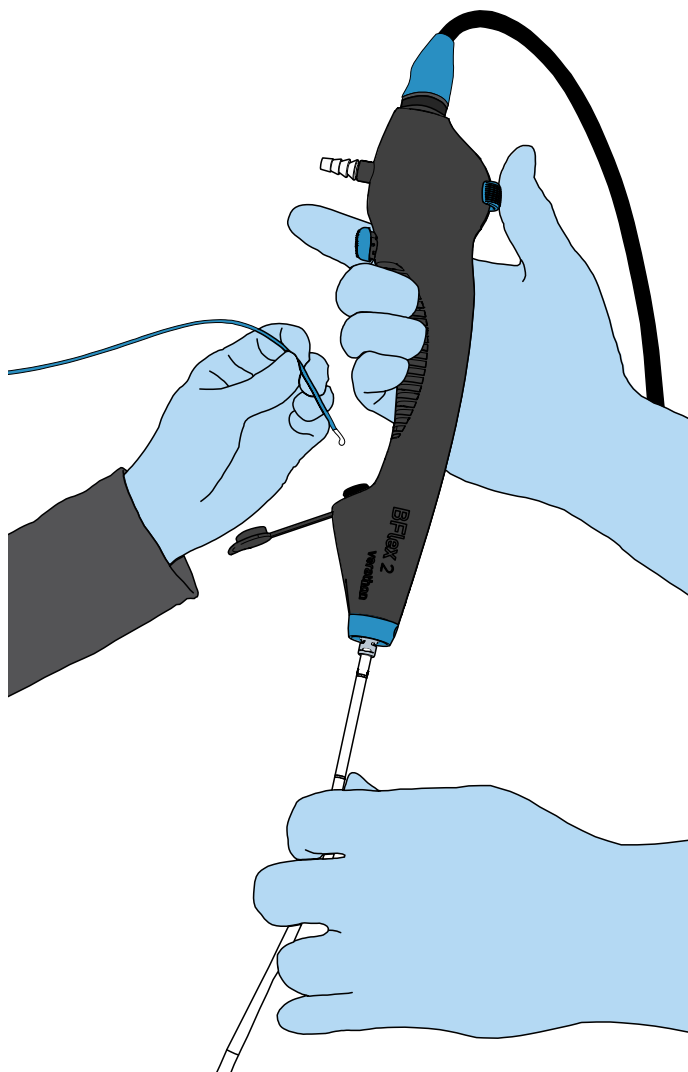

* Does not apply to BFlex 2 Ultraslim 2.8.

Procedure 3. Insert Through a Tube or Catheter (Optional)

IMPORTANT

Verathon has tested compatibility with water based, silicone based, and petroleum based lubricants.

The bronchoscope can be inserted through a tube or catheter with a compatible inside diameter, as shown in the following table.

Table 6. BFlex 2 Bronchoscope—Endotracheal Tube Compatibility

TUBES AND CATHETERS	SPECIFICATION	ULTRASLIM 2.8	SLIM 3.8	REGULAR 5.0	LARGE 5.8
Endotracheal tube	Minimum Inside Diameter	4.0 mm	5.0 mm	6.0 mm	7.0 mm
Percutaneous Dilatational Tracheostomy (PDT) tube	Minimum Inside Diameter	4.0 mm	5.0 mm	6.0 mm	7.0 mm
Double-Lumen tube	Minimum Size	32 Fr	35 Fr	Not supported	
Airway catheter	Minimum Size	19 Fr	19 Fr		
	Minimum Inside Diameter	4.7 mm	4.7 mm		
	Maximum length	560 mm	560 mm		
Bronchial blocker	Follow the bronchial blocker manufacturer's guidance for scope size compatibility.				

Note: There is no guarantee that instruments selected solely using these instrument dimensions will be compatible in combination. Importantly, The BFlex 2 Slim 3.8 Single-Use Bronchoscope should not be used with 35Fr Shiley Endobronchial Tubes. Damage or tear to BFlex 2 tip sheath may occur.

1. Remove your thumb from the positioning lever of the bronchoscope and ensure that the distal tip is completely straight and in a neutral position.
2. Lubricate the scope, tube, or catheter, and then slowly insert the distal tip of the bronchoscope into the internal channel of the tube or catheter. If you encounter resistance while inserting the bronchoscope, pull the scope back slightly, ensure your thumb is not on the positioning lever, and then continue inserting the bronchoscope.
If there is ongoing resistance, consider the following:
 - Apply additional lubrication to the scope, tube, or catheter.
 - Use a smaller diameter bronchoscope or a larger diameter tube or catheter.
3. As you slide the bronchoscope through the tube or catheter, keep your thumb off of the positioning lever until the monitor image and the markings on the bronchoscope indicate that the distal tip has emerged completely from the distal end of the tube or catheter.
4. After the distal tip has emerged from the tube or catheter, return your thumb to the positioning lever. Follow the positioning instructions in the following section, [Insert and Flex the Bronchoscope](#), to maneuver the tip to its working location.

- If you are using an endotracheal tube or double lumen tube, slide the tube's connector into the tube retainer of the bronchoscope, and then press it securely into place.

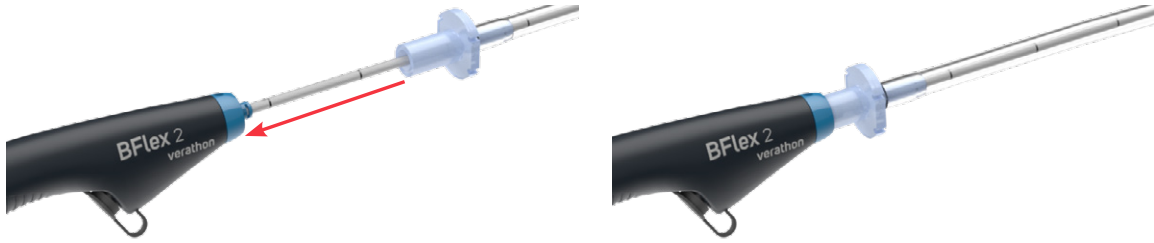

Procedure 4. Insert and Flex the Bronchoscope

The bronchoscope can be inserted using any standard oral or nasal insertion technique, with or without the use of a separate ET tube. During use, its distal tip can flex through the ranges shown in the following table.

Table 7. BFlex 2 Bronchoscope—Distal Tip Articulation

SIZE	RANGE OF MOVEMENT OF DISTAL TIP*
BFlex 2 Ultraslim 2.8	185° flex, 195° retroflex
BFlex 2 Slim 3.8	180° flex, 185° retroflex
BFlex 2 Regular 5.0	215° flex, 225° retroflex
BFlex 2 Large 5.8	190° flex, 205° retroflex

* Values shown are averages following the sterilization stage of manufacturing.

As you perform the insertion, use the following steps to direct the distal tip of the bronchoscope.

Note: If necessary, the bronchoscope can be wiped gently with sterile gauze.

- Using your thumb, move the positioning lever to flex the distal tip as needed. The tip flexes with the lever as shown in the figures to the right.
- As you carefully advance and flex the distal tip, rotate the handle around its long axis. By combining all three movements, you can direct the tip to any point in the direction of insertion.
- Observe the black markings on the insertion tube of the bronchoscope in order to determine depth. These markings are spaced at 5 cm intervals. The first mark appears at the inward edge of the tip itself, marking the tip as 10 cm long.



Flex

Retroflex

Procedure 5. Introduce Liquids or Accessories (Optional)



Please read the [Warnings & Cautions](#) section before performing the following task.

IMPORTANT

The BFlex 2 Ultraslim 2.8 does not have suction capability.

In addition to supplying suction, the working channel on the bronchoscope also provides a delivery channel for the following items:

- Liquids such as sterile saline solution
- Endoscopic tools that do not require their own source of electrical power (non-powered tools) such as forceps, cutters, baskets, or brushes

The following table shows minimum inside diameter of the working channel for each size of bronchoscope. For compatibility, please refer to tool or accessory manufacturer's documentation.

Table 8. BFlex 2 Bronchoscope—Minimum inside diameter of working channel

SIZE	MINIMUM INSIDE DIAMETER OF WORKING CHANNEL
BFlex 2 Ultraslim 2.8	Not applicable. No working channel.
BFlex 2 Slim 3.8	1.2 mm
BFlex 2 Regular 5.0	2.2 mm
BFlex 2 Large 5.8	3.0 mm

Use the following steps to introduce liquids or accessories through the working channel.

Option 1. Administering Liquids

1. Aspirate the solution into a syringe, if you have not already done so.
2. If you are using a slip-tip syringe to administer the liquid, fully insert the tip of the syringe into the accessory port. If you are using a luer lock syringe, use the included introducer to connect the syringe to the port.



3. Dispense the liquid into the working channel.

Note: If suction is connected to the bronchoscope, do not apply suction while you are introducing the liquid. This causes the suction to withdraw the liquid from the bronchoscope. Conversely, to ensure full suction strength, retract the syringe or introducer while applying suction.

Option 2. Introducing Non-Powered Endoscopic Accessories

1. Move the positioning lever in order to return the distal tip as close to a straight position as possible.
2. If appropriate, position the accessory so that its distal end is collapsed as far as possible.
3. Insert the distal end of the accessory into the working channel.



4. Slide the accessory through the working channel until its end emerges from the distal tip of the bronchoscope, as shown on the monitor screen.
5. Position the distal tip of the bronchoscope and the accessory as needed to perform the procedure.

Note: To ensure full suction strength, retract the accessory from the working channel before applying suction.

Procedure 6. Use the Record & Snapshot Features (Optional)



Please read the [Warnings & Cautions](#) section before performing the following task.

The system is equipped with video and audio recording features and the ability to save a snapshot of the live display on the monitor. The system saves this data to a USB flash drive, and you can view the recordings or snapshots on the video monitor or a computer.



By default, audio recording is disabled. If you would like the system to record audio in addition to video, complete the procedure [Configure User Settings](#) (page 27) to enter the User Settings screen, and then change the **Audio Recording** setting to **On**.

While recording, a number next to the icon indicates approximately what percentage of the USB flash drive has been used. When the USB flash drive is full, recording stops.

1. On the back of the monitor, remove the USB port cap, and then insert a USB flash drive into the port.

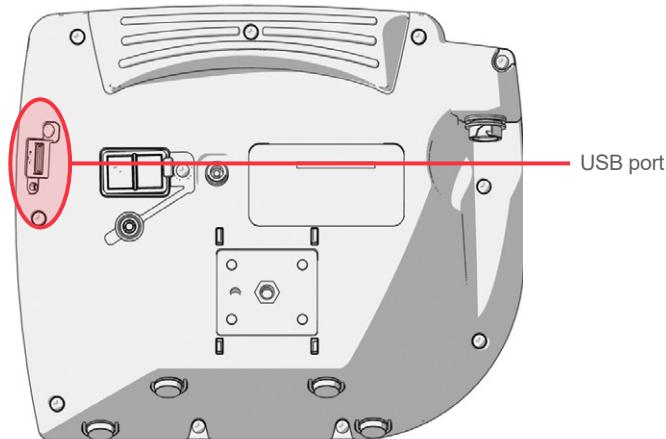
Note: If you do not insert a USB flash drive, the video recording, audio recording, and snapshot features will not be available.



2. Ensure that the USB flash drive is detected by checking if the **USB Flash Drive** icon  on the bottom of the screen is displayed.
3. If you want to record the intubation, press the **Record** button . Video recording starts and is saved to the USB flash drive.

If audio recording is enabled in the User Settings display, the **Audio Recording is Active** icon  will appear on the screen, and audio will be recorded with the video.

4. When you are finished recording, press the **Record** button  again, and then wait for the **Saving File** icon  to disappear.

Note: If you remove the USB flash drive before the Saving File icon disappears, the recording will be lost.

5. If at any point you would like to save a photo of the live display to the USB flash drive, press the **Snapshot** button , and then wait for the **Saving Snapshot** icon  to disappear.

Note: If you remove the USB flash drive before the Saving Snapshot icon disappears, the photo will be lost.

6. If you would like to review the recorded files on the video monitor, complete the steps in the procedure [Use the Playback Feature \(Optional\)](#) on page 39.

If you would like to review the recorded files on a computer, insert the USB flash drive into the PC, and then view the .avi or .jpg files.

Note:

If you are viewing the recorded file on a Windows operating system (OS), use an application such as Windows Media Player.

If you are viewing the recorded video file on Mac OS, use an application such as one of the following:

- MPlayerX (free in the App Store)
- VLC (free at <http://www.videolan.org/vlc/index.html>)

If you are viewing the recorded video file on iOS, use an application such as one of the following:

- VLC for iOS (free in the App Store)
- 8player lite (free in the App Store)
- Media Player - PlayerXtreme HD (free in the App Store)

Procedure 7. Remove the Bronchoscope

If you intend to use the bronchoscope with the same patient more than once, prepare a sterile resting area for it. If you are using a BFlex 2 with a BFlex holder, the holder can be used as an intra-operative storage location. Keep the bronchoscope in this area when it is not in use.

1. When possible, retract any accessories into the working channel in order to avoid interference with the distal tip during removal.
2. Return the positioning lever as close to center as possible, and then remove your thumb from the positioning lever.
3. Carefully withdraw the bronchoscope without touching the control lever.

Note: If you encounter resistance during withdrawal, reinsert the bronchoscope slightly, and then gently rotate it, straighten the tube, or instill saline into the tube, and then attempt removal again.

4. After you have withdrawn the bronchoscope completely, examine it thoroughly. Verify that it is not damaged and none of its components are missing.
5. If necessary, detach the cable from the bronchoscope by holding the cable connector in one hand and the bronchoscope handle in the other, and then pulling them straight apart.
6. When the procedure is complete, dispose of the bronchoscope according to your local protocols for bio-hazard waste.

Procedure 8. Use the Playback Feature (Optional)

Recorded videos and snapshots on a USB flash drive can be viewed on the GlideScope Video Monitor.

Note: The monitor cannot play back videos or display snapshots while a recording is in process.









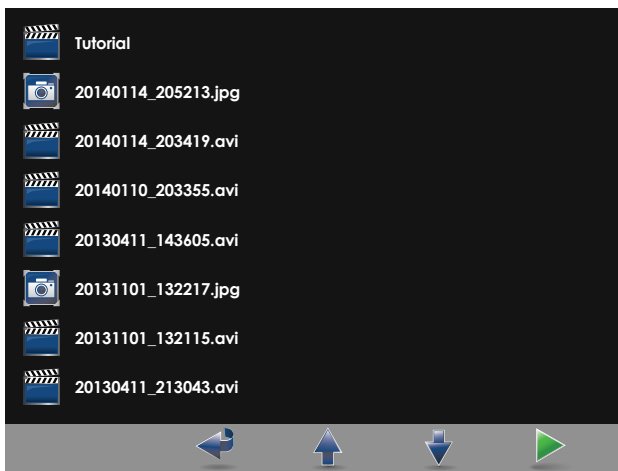

1. On the back of the monitor, remove the USB port cap, and then insert a USB flash drive into the port.
2. Ensure that the USB flash drive is detected by checking if the **USB Flash Drive** icon  on the bottom of the screen is displayed.
3. Press and hold the **Tutorial** button  3 seconds or longer. The playback menu is displayed.

Figure 11. Playback Menu



4. Navigate the menu as follows:
 - Press the **Snapshot** button  to move up the list of playback files.
 - Press the **External Video** button  to move down the list of playback files.
5. When you have selected the item that you want to play, press the **Tutorial** button . Playback starts.
6. When the file is being played back and is displayed on the screen, press the **Snapshot** button  to playback the next file above the one currently displayed. Press the **External Video** button  to play the next file below the one currently displayed.
7. If the file being played back is a video, pause and resume playback by pressing the **Tutorial** button .
8. Press the **Record** button  to return to the playback menu.
9. Press the **Record** button  again to close the playback menu.

Reprocessing

Some of the components in this manual may require cleaning, low-level disinfection, high-level disinfection, or sterilization between uses or under specific circumstances. For information about the cleaning, disinfection, and sterilization requirements for these components, refer to the GlideScope and GlideRite Products Reprocessing Manual, which is available at [verathon.com/service-and-support/glidescope-reprocessing-products](https://www.verathon.com/service-and-support/glidescope-reprocessing-products).

Maintenance & Safety

Periodic Inspections

No periodic inspections, maintenance, or calibrations are required by Verathon.

Report any suspected defects to Verathon Customer Care or your local representative. For contact information, visit verathon.com/service-and-support.

GlideScope Video Monitor Battery

Under normal operating conditions, the monitor battery will last 2–3 years, or approximately 500 charge and discharge cycles. For more information about the battery, see [Battery Specifications](#) on page 53.

The battery is not user-replaceable. In case of battery malfunction, do not attempt to replace the monitor battery. Any attempts to replace the battery by unauthorized service technicians may cause serious harm to the user and will void the warranty. Please contact your Verathon Customer Care representative for more information on battery replacement.

System Software

Verathon may release software upgrades for the GlideScope Video Monitor. Software upgrades are supplied directly by Verathon or an authorized representative, and installation instructions are provided with the upgrade.

This manual documents the most current version of the GlideScope Video Monitor software. If your monitor does not function as described in this manual, or to determine if your software should be updated, contact Verathon Customer Care.

Do not perform any software upgrades from third-party vendors or attempt to modify the existing software. Doing so may damage the monitor and void the warranty.

For information about software language options, see [Language Settings](#) on page 14.

Device Repair

The system components are not user-serviceable. Verathon does not make available any type of circuit diagrams, component parts lists, descriptions, or other information that would be required for repairing the device and related accessories. All service must be performed by a qualified technician.

If you have any questions, contact your local Verathon representative or Verathon Customer Care.



Please read the [Warnings & Cautions](#) section.

Device Disposal

The system and related accessories may contain batteries and other environmentally hazardous materials. When the instrument has reached the end of its useful service life, it must be disposed of in accordance with WEEE requirements. Coordinate disposal through your Verathon Service Center, or alternatively, follow your local protocols for hazardous waste disposal.

Warranty

ORIGINAL FIRST YEAR TOTAL CUSTOMER CARE WARRANTY

Verathon warrants the system against defects in material and workmanship. The limited warranty applies for one (1) year from the date of shipment from Verathon and applies only to the original purchaser of the system. The terms of this warranty are subject to the *Terms and Conditions of Sale* or any other contractual document between the parties.

Verathon's policy is to honor product warranties and to perform services only on products purchased from an authorized Verathon dealer. If you purchase a Verathon product or system components from an unauthorized dealer or if the original factory serial number has been removed, defaced or altered, your Verathon warranty will be void. Purchasing Verathon products from unauthorized entities could result in receipt of product that is counterfeit, stolen, used, defective, or not intended for use in your region.

If a customer's system requires service or repair, Verathon will, at its discretion, either repair or replace the customer's unit and provide a loaner unit. The customer agrees to send the defective unit to Verathon (cleaned and disinfected as appropriate) upon receipt of the loaner unit, and the customer agrees to return the loaner unit within two (2) business days of receipt of the repaired unit. All exchanged parts become property of Verathon.

Each product manufactured by Verathon is warranted to be free from defects in material and workmanship under normal use and services. Verathon's warranty does not cover defects or problems caused by the buyer's acts (or failure to act), the acts of others, or events beyond Verathon's reasonable control. The buyer shall be solely responsible, for any problem, failure, malfunction, defect, claim, damage, liability, or safety issue arising out of the following:

- Accident, theft, misuse, abuse, extraordinary wear and tear, or neglect.
- Misapplication, improper use, or other failure to follow Verathon's product instructions and safety precautions. The system shall be used in accordance with the instructions contained in this manual. This warranty does not apply if there is evidence of the equipment being exposed to temperatures in excess of 60°C (140°F).
- Use of the system in conjunction with hardware, software, components, services, accessories, attachments, interfaces, or consumables, other than those supplied or specified by Verathon.
- Products that have been repaired or maintained by anyone other than a Verathon authorized service provider. Modification, disassembly, rewiring, re-engineering, recalibration, and/or reprogramming of products other than as specifically authorized by Verathon in writing is prohibited and will void all warranties.

This warranty provides coverage if the instrument is rendered inoperable as a result of an accidental drop or mishandling after payment by the buyer of the current deductible as determined by Verathon. The deductible charge will be applied on each warranty request and may be applied an unlimited number of times per instrument.

WHAT IS COVERED?

Warranty coverage applies to the following system components:

- GlideScope Video Monitor
- GlideScope Video Monitor QuickConnect Cable

Additional reusable components purchased either singularly or as a part of a system are warranted separately. Consumable items are not covered under this warranty.

PREMIUM CUSTOMER CARE WARRANTY

You may purchase a Premium Total Customer Care warranty that extends the limited warranty. For more information, contact Verathon Customer Care or your local representative.

DISCLAIMER OF ADDITIONAL WARRANTIES

There are no understandings, agreements, representations of warranties expressed or implied (including warranties of merchantability or fitness for a particular purpose) other than those set forth in this chapter and the *Terms and Conditions of Sale*. The contents of this manual do not constitute a warranty.

Some states disallow certain limitations on applied warranties. The purchaser should consult state law if there is a question regarding this disclaimer. The information, descriptions, recommendations, and safety notations in this manual are based upon Verathon experience and judgment. The contents of this manual should not be considered to be all-inclusive or to cover all contingencies.

Product Specifications



Please read the [Warnings & Cautions](#) section.

Component Specifications

Table 9. *GlideScope Video Monitor (0570-0338)*

GENERAL SPECIFICATIONS		
Classification:	Electrical Class II, Applied Part BF	
Line voltage:	Range: 100–240 VAC, 50 and 60 Hz. Connect to a medical-grade power supply (If the provided power cord has a third prong, it is used as a functional ground).	
DC power supply:	12 V DC, 3.33 A max	
Ingress protection:	IP54	
OPERATING & STORAGE SPECIFICATIONS		
	Operating Conditions	Shipping & Storage Conditions
Temperature:	10–40°C (50–104°F)	-20–45°C (-4–113°F)
Relative humidity:	10–95%	10–95%
Atmospheric pressure:	700–1060 hPa	440-1060 hPa
COMPONENT SPECIFICATIONS		
Screen type and resolution	TFT Color VGA 640 × 480 px	
Screen size (diagonal; A)	16.3 cm (6.4 in)	
Height (B)	174 mm	
Width (C)	223 mm	
Depth (D)	80 mm	
Weight	1.0 kg	

Table 10. *GlideScope Video Monitor QuickConnect Cable (0600-0781)*

GENERAL SPECIFICATIONS		
Ingress protection:	IPX7	
OPERATING, SHIPPING, & STORAGE SPECIFICATIONS		
	Operating Conditions	Shipping & Storage Conditions
Temperature:	10–40°C (50–104°F)	-20–45°C (-4–113°F)
Relative humidity:	10–95%	10–95%
Atmospheric pressure:	700–1060 hPa	440-1060 hPa
COMPONENT SPECIFICATIONS		
Length (A)	1931 mm	
Diameter (B)	6.8 mm	

Table 11. *Premium Cart (0800-0537)*

OPERATING, SHIPPING, & STORAGE SPECIFICATIONS		
	Operating Conditions	Shipping & Storage Conditions
Temperature:	10–40°C (50–104°F)	-20–45°C (-4–113°F)
Relative humidity:	10–95%	10–95%
Atmospheric pressure:	700–1060 hPa	440-1060 hPa
COMPONENT SPECIFICATIONS		
Wheelbase diameter (A)	53.3 cm	
Minimum height (B)	101.6 cm	
Maximum height (C)	132.1 cm	
Weight	8.0–8.4 kg	

Table 12. Mobile Stand (0800-0410)

OPERATING, SHIPPING, & STORAGE SPECIFICATIONS		
	Operating Conditions	Shipping & Storage Conditions
Temperature:	10–40°C (50–104°F)	-20–45°C (-4–113°F)
Relative humidity:	10–95%	10–95%
Atmospheric pressure:	700–1060 hPa	440-1060 hPa
COMPONENT SPECIFICATIONS		
Wheelbase diameter (A)	61 cm	
Minimum height (B)	76 cm	
Maximum height (C)	122 cm	



Table 13. IV Pole Mount (0810-0200)

OPERATING, SHIPPING, & STORAGE SPECIFICATIONS		
	Operating Conditions	Shipping & Storage Conditions
Temperature:	10–40°C (50–104°F)	-20–45°C (-4–113°F)
Relative humidity:	10–95%	10–95%
Atmospheric pressure:	700–1060 hPa	440-1060 hPa
COMPONENT SPECIFICATIONS		
Arm length (A)	27 cm	
Width (B)	6.3 cm	
Pole width range (C)	6.4–33 mm	
Weight	0.9 kg	

Table 14. BFlex Holder for GVM (0810-0294)

OPERATING, SHIPPING, & STORAGE SPECIFICATIONS		
	Operating Conditions	Shipping Conditions
Temperature:	10–40°C (50–104°F)	-20–45°C (-4–113°F)
Relative humidity:	10–95%	10–95%
Atmospheric pressure:	700–1060 hPa	440-1060 hPa
COMPONENT SPECIFICATIONS		
Arm length (A)	152.1 mm (6.0 in)	
Pole width range (B)	19–38 (0.75–1.5 in)	
Weight	0.19 kg	

Table 15. BFlex 2 Ultraslim 2.8 (0570-0434)

GENERAL SPECIFICATIONS			
Ingress protection:	IPX0		
Expected product life:	Refer to the “use by” date indicated by the ⏳ symbol on the package label.		
OPERATING, SHIPPING, & STORAGE SPECIFICATIONS			
	Operating Conditions	Shipping Conditions	Storage Conditions
Temperature:	10–40°C (50–104°F)	-20–45°C (-4–113°F)	18–28°C (64–82°F)
Relative humidity:	10–95%	10–95%	40–60%
Atmospheric pressure:	700–1060 hPa	440–1060 hPa	1013 hPa
COMPONENT SPECIFICATIONS			
Specification	Value		
Length of flexible insertion tube from distal tip (A)	610 mm		
Outside diameter of flexible insertion tube (B)	2.8 mm		
Maximum outside diameter of flexible insertion tube and distal tip (C)	3.3 mm		
Minimum inside diameter of endotracheal tube	4.0 mm		
Depth of field (D)	5–50 mm		
Direction of view, relative to center line of distal tip	0°		
Field of view, horizontal/vertical (E)	85°		
Field of view, diagonal (F)	120°		

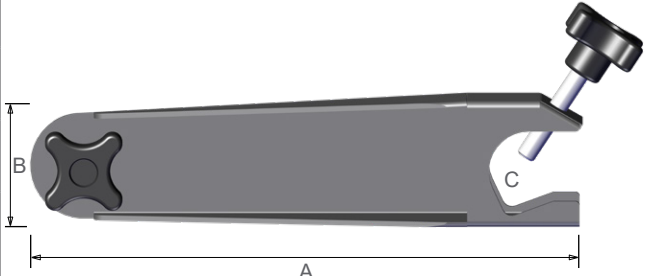
Table 16. BFlex 2 Slim 3.8 (0570-0432)

GENERAL SPECIFICATIONS			
Ingress protection:	IPX0		
Expected product life:	Refer to the “use by” date indicated by the ⏳ symbol on the package label.		
OPERATING, SHIPPING, & STORAGE SPECIFICATIONS			
	Operating Conditions	Shipping Conditions	Storage Conditions
Temperature:	10–40°C (50–104°F)	-20–45°C (-4–113°F)	18–28°C (64–82°F)
Relative humidity:	10–95%	10–95%	40–60%
Atmospheric pressure:	700–1060 hPa	440–1060 hPa	1013 hPa
COMPONENT SPECIFICATIONS			
Specification	Value		
Length of flexible insertion tube from distal tip (A)	610 mm		
Outside diameter of flexible insertion tube (B)	3.8 mm		
Maximum outside diameter of flexible insertion tube and distal tip (C)	4.4 mm		
Minimum inside diameter of endotracheal tube	5.0 mm		
Average Inside diameter of working channel (D)	1.2 mm		
Minimum inside diameter of working channel (D)	1.2 mm*		
Maximum accessory width	1.0 mm		
Length of working channel	696 mm†		
Volume of working channel	0.98 cc (0.98 mL)		
Depth of field (E)	5–50 mm		
Direction of view, relative to center line of distal tip	0°		
Field of view, horizontal/vertical (F)	85°		
Field of view, diagonal (G)	120°		

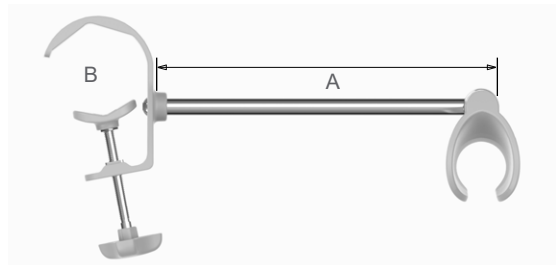
* There is no guarantee that accessories selected solely using this minimum instrument channel width will be compatible in combination.

† There is no guarantee that accessories selected solely using maximum insertion portion width and working length will be compatible in combination.

Table 17. BFlex 2 Regular 5.0 (0570-0423)

GENERAL SPECIFICATIONS			
Ingress protection:	IPX0		
Expected product life:	Refer to the “use by” date indicated by the ⏳ symbol on the package label.		
OPERATING, SHIPPING, & STORAGE SPECIFICATIONS			
	Operating Conditions	Shipping Conditions	Storage Conditions
Temperature:	10–40°C (50–104°F)	-20–45°C (-4–113°F)	18–28°C (64–82°F)
Relative humidity:	10–95%	10–95%	40–60%
Atmospheric pressure:	700–1060 hPa	440–1060 hPa	1013 hPa
COMPONENT SPECIFICATIONS			
Specification	Value		
Length of flexible insertion tube from distal tip (A)	610 mm		
Outside diameter of flexible insertion tube (B)	5.0 mm		
Maximum outside diameter of flexible insertion tube and distal tip (C)	5.5 mm		
Minimum inside diameter of endotracheal tube	6.0 mm		
Average inside diameter of working channel (D)	2.2 mm		
Minimum inside diameter of working channel (D)	2.2 mm*		
Maximum accessory width	2.0 mm		
Length of working channel	696 mm†		
Volume of working channel	2.77 cc (2.77 mL)		
Depth of field (E)	5–50 mm		
Direction of view, relative to center line of distal tip	0°		
Field of view, horizontal/vertical (F)	85°		
Field of view, diagonal (G)	120°		

* There is no guarantee that accessories selected solely using this minimum instrument channel width will be compatible in combination.

† There is no guarantee that accessories selected solely using maximum insertion portion width and working length will be compatible in combination.

Table 18. BFlex 2 Large 5.8 (0570-0424)

GENERAL SPECIFICATIONS			
Ingress protection:	IPX0		
Expected product life:	Refer to the “use by” date indicated by the ⏳ symbol on the package label.		
OPERATING, SHIPPING, & STORAGE SPECIFICATIONS			
	Operating Conditions	Shipping Conditions	Storage Conditions
Temperature:	10–40°C (50–104°F)	-20–45°C (-4–113°F)	18–28°C (64–82°F)
Relative humidity:	10–95%	10–95%	40–60%
Atmospheric pressure:	700–1060 hPa	440–1060 hPa	1013 hPa
COMPONENT SPECIFICATIONS			
Specification	Value		
Length of flexible insertion tube from distal tip (A)	610 mm		
Outside diameter of flexible insertion tube (B)	5.8 mm		
Maximum outside diameter of flexible insertion tube and distal tip (C)	6.35 mm		
Minimum inside diameter of endotracheal tube	7.0 mm		
Average inside diameter of working channel (D)	3.0 mm		
Minimum inside diameter of working channel (D)	3.0 mm*		
Maximum accessory width	2.6 mm		
Length of working channel	696 mm†		
Volume of working channel	5.2 cc (5.2 mL)		
Depth of field (E)	5–50 mm		
Direction of view, relative to center line of distal tip	0°		
Field of view, horizontal/vertical (F)	85°		
Field of view, diagonal (G)	120°		

* There is no guarantee that accessories selected solely using this minimum instrument channel width will be compatible in combination.

† There is no guarantee that accessories selected solely using maximum insertion portion width and working length will be compatible in combination.

Battery Specifications

Table 19. Monitor Battery Specifications

CONDITION	DESCRIPTION
Battery type	Lithium-ion
Battery life	Under normal operating conditions, a fully charged battery lasts approximately 90 minutes
Charging time	Charging time off line will take no more than 6 hours from an empty battery to a full charge
Rated capacity	2150 mAh
Nominal voltage	7.2 V
Max charging voltage	8.4 V
Nominal weight	90 g (0.2 lbs)
Width	23 mm (0.9 in)
Length	391 mm (5.4 in)
Thickness	23 mm (0.9 in)

Electromagnetic Compatibility

The BFlex 2 system is designed to be in compliance with IEC 60601-1-2, which contains electromagnetic compatibility (EMC) requirements for medical electrical equipment. The limits for emissions and immunity specified in this standard are designed to provide reasonable protection against harmful interference in a typical medical installation.

The system complies with the applicable essential performance requirements specified in IEC 60601-1 and IEC 60601-2-18. Results of immunity testing show that the essential performance of the system is not affected under the test conditions described in the following tables. For more information about the essential performance of the BFlex 2 system, see [Essential Performance](#) on page 2.

Electromagnetic emissions

Table 20. Guidance and Manufacturer’s Declaration—Electromagnetic Emissions

The system is intended for use in the electromagnetic environment specified below. The customer or the user of the system should ensure that it is used in such an environment.

EMISSIONS TEST	COMPLIANCE	ELECTROMAGNETIC ENVIRONMENT – GUIDANCE
RF emissions CISPR 11	Group 1	The system uses RF energy only for its internal function. Therefore, its RF emissions are very low and are not likely to cause any interference in nearby electronic equipment.
RF emissions CISPR 11	Class A	The system is suitable for use in all establishments other than domestic and those directly connected to the public low-voltage power supply network that supplies buildings used for domestic purposes.
Harmonic emissions IEC 61000-3-2	Class A	
Voltage fluctuations/ flicker emissions IEC 61000-3-3	In compliance	

Electromagnetic immunity

Table 21. Guidance and Manufacturer's Declaration—Electromagnetic Immunity

The system is intended for use in the electromagnetic environment specified below. The customer or the user of the system should ensure that it is used in such an environment.

IMMUNITY TESTS	IEC 60601 TEST LEVEL	COMPLIANCE LEVEL	ELECTROMAGNETIC ENVIRONMENT – GUIDANCE
Electrostatic discharge (ESD) IEC 61000-4-2	± 8 kV contact ± 15 kV air	In compliance	Floors should be wood, concrete, or ceramic tile. If floors are covered with synthetic material, the relative humidity should be at least 30%.
Electrical fast transient/burst IEC 61000-4-4	± 2 kV for power supply lines 100 kHz repetition frequency	In compliance	Mains power quality should be that of a typical hospital environment.
Surge IEC 61000-4-5	± 1 kV line(s) to line(s) ± 2 kV line(s) to earth	In compliance	Mains power quality should be that of a typical hospital environment.
Voltage dips, short interruptions and voltage variations on power supply input lines IEC 61000-4-11	0% U_T ; 0.5 Cycle At 0°, 45°, 90°, 135°, 180°, 225°, 270°, and 315° 0% U_T ; 1 cycle and 70% U_T ; 25/30 cycles Single Phase: at 0°	In compliance	Mains power quality should be that of a typical hospital environment. If the user of the system requires continued operation during power mains interruptions, it is recommended that the system be powered from an uninterruptible power supply or a battery.
Rated power frequency magnetic fields IEC 61000-4-8	30 A/m Frequency 50/60 Hz	In compliance	Power frequency magnetic fields should be at levels characteristic of a typical location in a typical hospital environment.
Conducted RF IEC 61000-4-6	3 Vrms 150 kHz to 80 MHz 6Vrms in ISM bands 150 kHz to 80 MHz 80% AM at 1 kHz	In compliance	Portable and mobile RF communications equipment should be used no closer to any part of the system, including cables, than the recommended separation distance calculated from the equation applicable to the frequency of the transmitter. Recommended separation distance d (m) $d=1.2 \sqrt{P}$

Table 21. Guidance and Manufacturer’s Declaration—Electromagnetic Immunity

The system is intended for use in the electromagnetic environment specified below. The customer or the user of the system should ensure that it is used in such an environment.

IMMUNITY TESTS	IEC 60601 TEST LEVEL	COMPLIANCE LEVEL	ELECTROMAGNETIC ENVIRONMENT – GUIDANCE
Radiated RF IEC 61000-4-3	3 V/m 80 MHz to 2.7 GHz 80% AM at 1 kHz	In compliance	Interference may occur in the vicinity of equipment marked with the following symbol: 

Note: U_T is the AC mains voltage prior to application of the test level.

These guidelines may not apply in all situations. Electromagnetic propagation is affected by absorption and reflection from structures, objects and people.

Accessory Conformance to Standards

To maintain electromagnetic interference (EMI) within certified limits, the system must be used with the cables, components, and accessories specified or supplied by Verathon. For additional information, see the [Parts & Accessories](#) section on page 12 and [Component Specifications](#) section on page 45. The use of accessories or cables other than those specified or supplied may result in increased emissions or decreased immunity of the system.

Table 22. EMC Standards for Accessories

ACCESSORY	MAX LENGTH
AC power cord	4.5 m (15.0 ft)
DC medical power adapter	2.5 m (8.2 ft)
HDMI-to-DVI cable	4.6 m (15.1 ft)
GlideScope Video Monitor QuickConnect Cable	1.5 m (4.9 ft)

Glossary

The following table provides definitions for specialized terms used in this manual or on the product itself. For a full list of caution, warning, and informational symbols used on this and other Verathon products, please refer to the Verathon Symbol Directory at verathon.com/service-and-support/symbols.

TERM	DEFINITION
A	Ampere
AC	Alternating current
AER	Automated endoscope reprocessor
C	Celsius
CFR	Code of Federal Regulations (U.S.)
CISPR	International Special Committee on Radio Interference
cm	Centimeter
CSA	Canadian Standards Association
DL	Direct laryngoscopy
DLT	Double-Lumen tube
EMI	Electromagnetic interference
ESD	Electrostatic discharge
Essential performance	The system performance necessary to achieve freedom from unacceptable risk
ET Tube	Endotracheal tube
F	Fahrenheit
g	Gram
GHz	Gigahertz
HDMI	High-definition multimedia interface
hPa	Hectopascal
Hz	Hertz
IEC	International Electrotechnical Commission
in	Inch
ISM	Industrial, scientific, and medical
ISO	International Standards Organization.
ISO connector	An endotracheal tube connector designed according to ISO standards.
kHz	Kilohertz
kPa	Kilopascal
kV	Kilovolt
L	Liter
m	Meter
mAh	Milliampere-hour
MDD	Medical Device Directive

TERM	DEFINITION
MHz	Megahertz
mm	Millimeter
mmHg	Millimeters of mercury
non-powered accessory	Endoscopic tool that does not require its own source of electrical power
OSHA	Occupational Safety and Health Administration (federal agency in U.S.)
powered accessory	Endoscopic tool that requires its own source of electrical power
RF	Radio frequency
RH	Relative humidity
SDS	Sodium dodecyl sulphate
V	Volt
Vrms	Voltage root mean squared
W	Watt
WEEE	Waste electrical and electronic equipment

verathon